

Chapter 8: 24, 26, 40, 46, 67, 68, 73, 74, 80, 82, 87, 88, 94, 98, 100, 109, 128

24. a. Rb < K < Na
 b. Ga < B < O
 c. Br < Cl < F
 d. S < O < F
26. a. Sn-H
 b. Tl-Br
 c. Si-O
 d. O-F
40. a. $V > V^{2+} > V^{3+} > V^{5+}$
 b. $Cs^+ > Rb^+ > K^+ > Na^+$
 c. $Te^{2-} > I^- > Cs^+ > Ba^{2+}$
 d. $P^{3-} > P^{2-} > P^- > P$
 e. $Te^{2-} > Se^{2-} > S^{2-} > O^{2-}$

46.

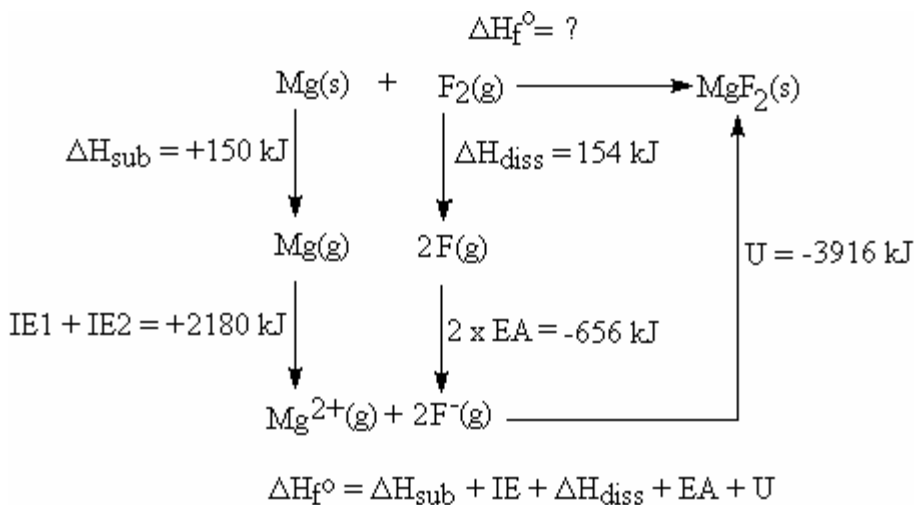

$$\Delta H_f^\circ = 150 + 2180 + 154 + (-656) + (-3916)$$

$$\Delta H_f^\circ = \mathbf{-2088 \text{ kJ}}$$

67.

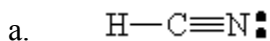

b.

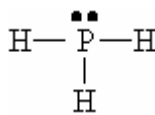

c.

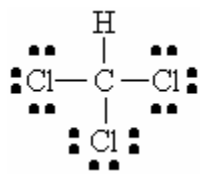

d.

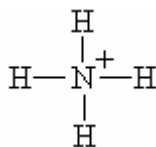

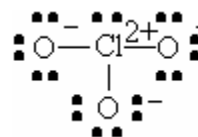
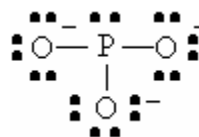
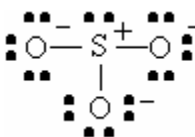
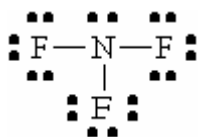
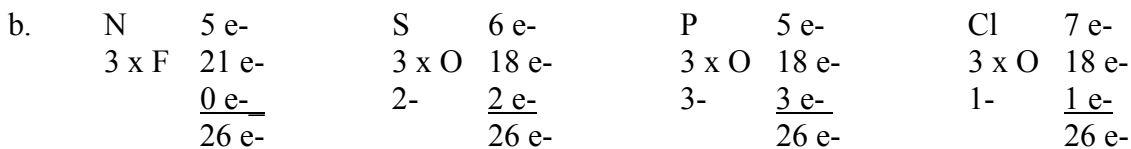
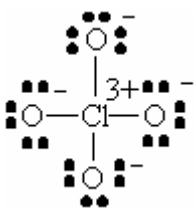
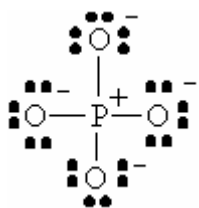
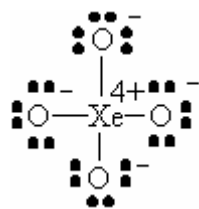
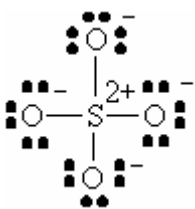
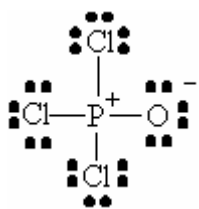
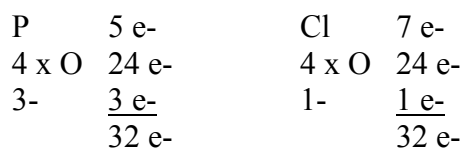
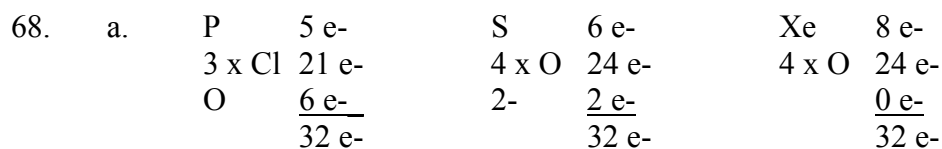
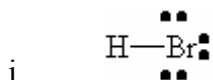
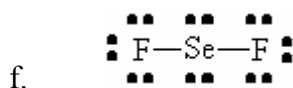
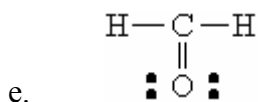

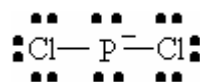
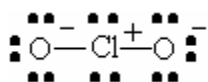
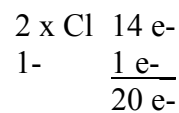
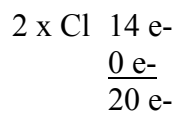
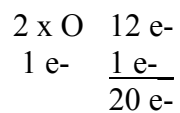

d. Same number of e⁻, same structure.

73.

a.

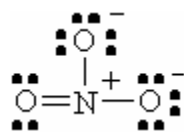
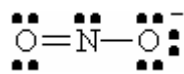

b.

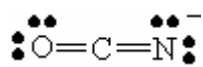

or

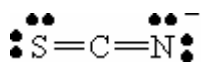
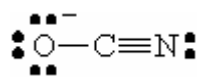

or

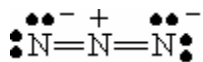
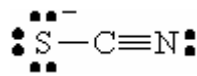

74.

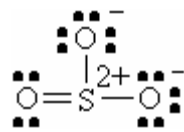
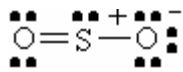
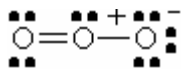

80.

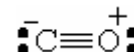
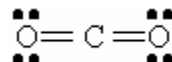
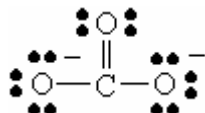
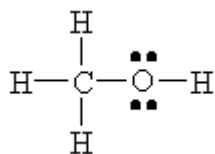

1
longest
1
weakest

2
2

3
3

4
shortest
4
strongest

81.

a.

82.

a.

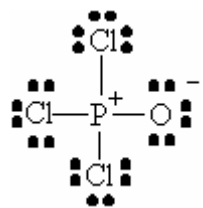

b.

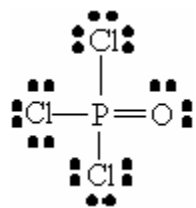

b.

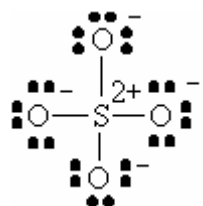

c.

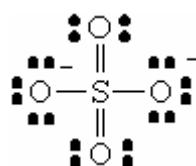

c.

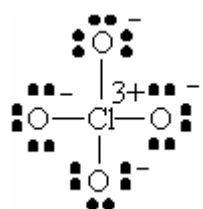

d.

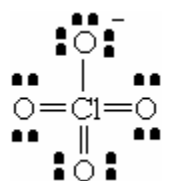

d.

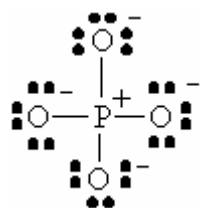

e.

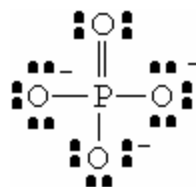

e.

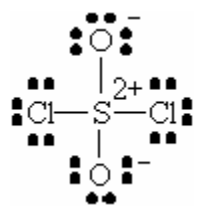

f.

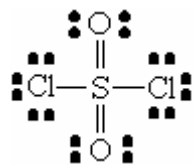

f.

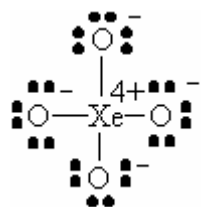

g.

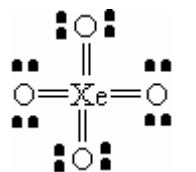

g.

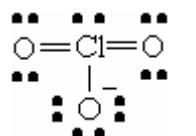
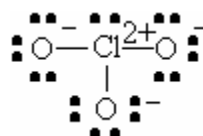

h.

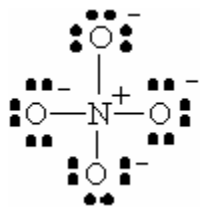

h.

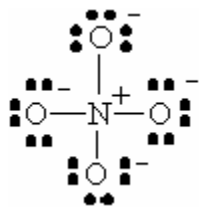

87.

- a. 2 regions linear no lone-pairs - linear 180°
 b. 4 regions tetrahedral 1 lone-pair - trigonal pyramid 109.5°

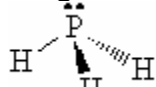

- c. 4 regions tetrahedral no lone-pair - tetrahedral 109.5°

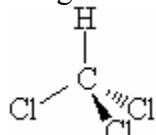

- d. 4 regions tetrahedral no lone-pair - tetrahedral 109.5°

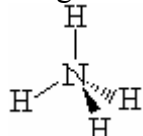

- e. 3 regions trigonal planar no lone-pair - trigonal planar 120°

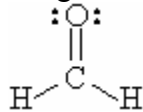

- f. 4 regions tetrahedral 2 lone-pair - bent 109.5°

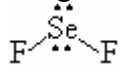

- g. 2 regions linear no lone-pairs - linear 180°

- h. 2 atoms linear 180°

- i. 2 atoms linear 180°

- a. 3 regions trigonal planar 1 lone-pair - bent 120°

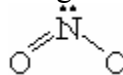

- 3 regions trigonal planar no lone-pair - trigonal planar 120°

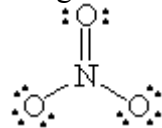

- b. 2 regions linear no lone-pairs - linear 180°

- 2 regions linear no lone-pairs - linear 180°

- 2 regions linear no lone-pairs - linear 180°

88.

- a. 4 regions tetrahedral no lone-pair - tetrahedral 109.5°

4 regions	tetrahedral	no lone-pair - tetrahedral	109.5°
4 regions	tetrahedral	no lone-pair - tetrahedral	109.5°
4 regions	tetrahedral	no lone-pair - tetrahedral	109.5°
4 regions	tetrahedral	no lone-pair - tetrahedral	109.5°

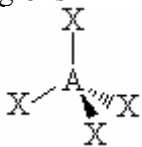

All

b.	4 regions	tetrahedral	1 lone-pair - trigonal pyramid	<109.5°
	4 regions	tetrahedral	1 lone-pair - trigonal pyramid	<109.5°
	4 regions	tetrahedral	1 lone-pair - trigonal pyramid	<109.5°



All

c.	4 regions	tetrahedral	2 lone-pair - bent	<109.5°
	4 regions	tetrahedral	2 lone-pair - bent	<109.5°
	4 regions	tetrahedral	2 lone-pair - bent	<109.5°



All

	3 regions	trigonal planar	1 lone-pair - bent	120°
	3 regions	trigonal planar	1 lone-pair - bent	120°



Both

	3 regions	trigonal planar	no lone-pair - trigonal planar	120°
--	-----------	-----------------	--------------------------------	------

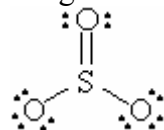

94.

a.	6 regions	octahedral	1 lone-pair - square pyramid	90°
----	-----------	------------	------------------------------	-----

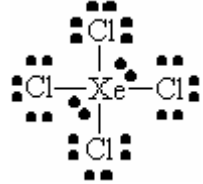
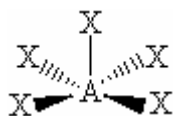
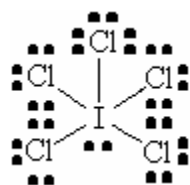

b.

	6 regions	octahedral	2 lone-pair - square planar	90°
--	-----------	------------	-----------------------------	-----



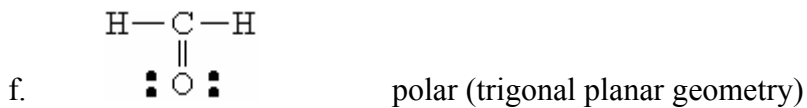
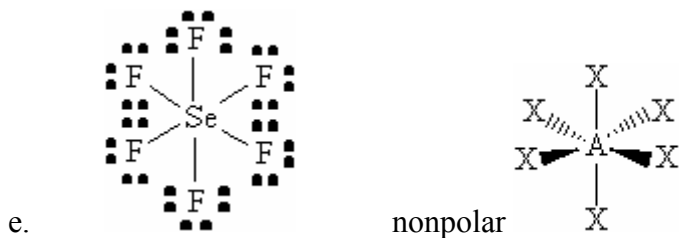
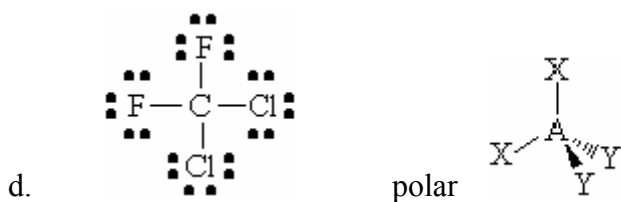
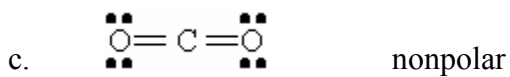
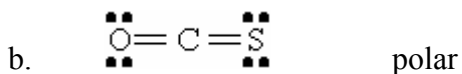
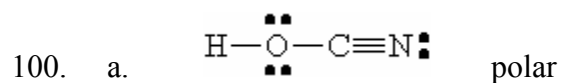
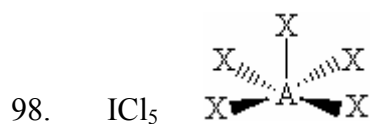
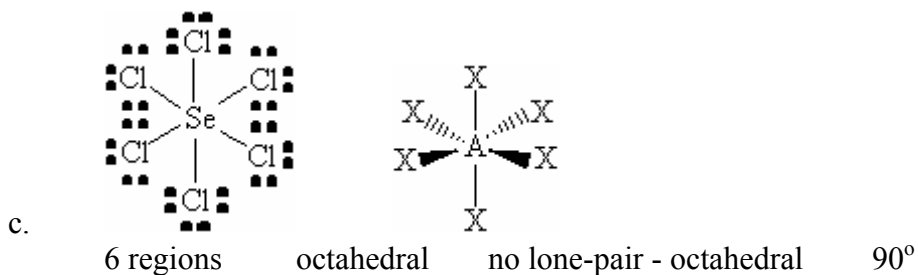

109. a. NaBr , too much energy needed to make Na^{2+} .
 b. ClO_4^- , ClO_4 has an odd number of e-.
 c. XeO_4 , too few e- (30) to complete octet.

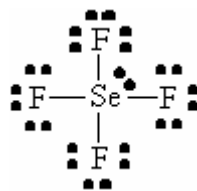

d. SeF_4 , O cannot hold $> 8 e^-$.

128.

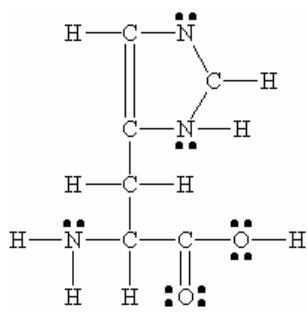

1	120°
2	109.5°